

SERIES: PSF-155 | **DESCRIPTION:** AC-DC POWER SUPPLY

FEATURES

- up to 155 W continuous power
- universal input (90~264 Vac)
- built-in constant current limit circuitry
- alarm signal for AC OK and battery low
- short circuit, over load, over voltage, brown-out, battery low, and battery polarity protections
- withstand 2G vibration test
- efficiency up to 86%



MODEL		output voltage	output current ¹	output power ²	ripple and noise ³	efficiency
		(Vdc)	max (A)	max (W)	max (mVp-p)	typ (%)
PSF-155-A	Vo1	13.8	11.2	155	100	86
	Vo2	13.8	3.88		150	
PSF-155-B	Vo1	13.8	10.1	155	100	85
	Vo2	13.8	3.88		150	
	Vo3	5	3		100	
PSF-155-C	Vo1	27.6	5.6	155	100	86
	Vo2	27.6	2.1		150	
PSF-155-D	Vo1	27.6	5.1	155	100	85
	Vo2	27.6	2.1		150	
	Vo3	5	3		100	

Notes: 1. Vo2 battery discharge current must not exceed 40% of the rated power.
 2. Maximum total combined power (rated power).
 3. At 20 MHz bandwidth using a 12" twisted pair-wire, each output terminated with a 47 µF and 0.1 µF parallel capacitors.

PART NUMBER KEY

PSF-155 - X - XXX

Base Number

Output Voltage
 A = 13.8 Vdc, 13.8 Vdc
 B = 13.8 Vdc, 13.8 Vdc, 5 Vdc
 C = 27.6 Vdc, 27.6 Vdc
 D = 27.6 Vdc, 27.6 Vdc, 5 Vdc

Chassis
 CNF = enclosed
 CF = enclosed with fan

INPUT

parameter	conditions/description	min	typ	max	units
voltage		90 127		264 373	Vac Vdc
surge voltage	for maximum of 5 seconds			300	Vac
frequency		47		63	Hz
current	at 115 Vac at 230 Vac		2.5 1.5		A A
inrush current	at 115 Vac, cold start at 230 Vac, cold start		55 108		A A
leakage current	at 264 Vac			1	mA
power factor	at full load	0.94			

OUTPUT

parameter	conditions/description	min	typ	max	units
line regulation	low line to high line, at rated load Vo1, Vo3		±0.5		%
load regulation	10% to 100% rated load Vo1 Vo3		±0.5 ±1.5		% %
voltage accuracy	Vo1 Vo3		±2 ±3		% %
hold-up time	at 115/230 Vac, full load		30		ms
setup time	at 115 Vac, full load, cold start at 230 Vac, full load, cold start	3200 2400			ms ms
rise time	at 115/230 Vac, full load		20		ms
adjustability	Vo1		±10		%
temperature coefficient	Vo1, 0°C~50°C		±0.03		%/°C
AC OK	PSF-155-A, PSF-155-C PSF-155-B, PSF-155-D		TTL open collector output relay contact output		
battery low	PSF-155-A, PSF-155-B PSF-155-C, PSF-155-D		<12 V ±3% <22 V ±3%		

PROTECTIONS

parameter	conditions/description	min	typ	max	units
over voltage protection	Vo1, latch off mode	115		150	%
over current protection	auto recovery, hiccup mode Vo1, Vo3 Vo2	110 100			% %
battery cut off	PSF-155-A, PSF-155-B PSF-155-C, PSF-155-D	9.6 19	10 20	10.4 21	Vdc Vdc

SAFETY & COMPLIANCE

parameter	conditions/description	min	typ	max	units
isolation voltage	input to output input to ground output to ground	3,000 1,500 500			Vac Vac Vac
isolation resistance	input to output at 500 Vdc	100			MΩ
safety approvals	UL 60950-1, EN 60950-1				
EMI/EMC ¹	EN 55022, EN 61000-6-(1,3), EN 61000-3-(2,3), EN 55024, EN 50204, EN 61204-3, EN 61000-4-(2, 3, 4, 5, 6, 8, 11)				
RoHS	2011/65/EU				

Note: 1. The power supply is considered a component which will be installed into a final equipment. The final equipment must be re-confirmed that it still meets EMC directives.

ENVIRONMENTAL

parameter	conditions/description	min	typ	max	units
operating temperature	see derating curve	-20		70	°C
storage temperature		-40		85	°C
operating humidity	non-condensing	20		90	%
storage humidity	non-condensing	10		90	%
vibration	at 10~500 Hz, 10 min per cycle for 60 minutes each test along the X, Y, and Z axis		2		G

DERATING CURVES

Load vs. Temperature

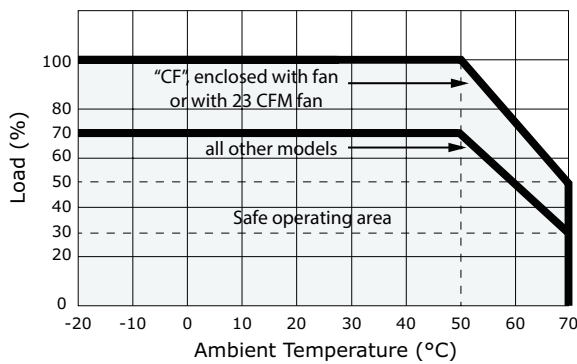

Load vs. Input Voltage (at 25°C)

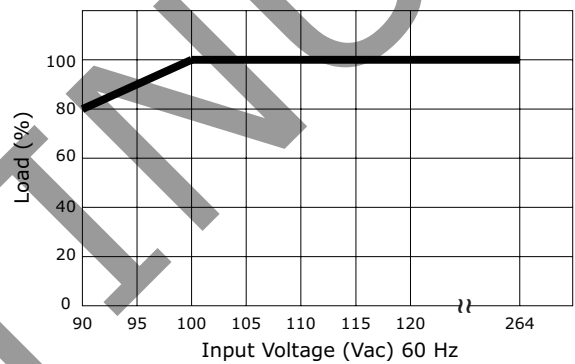

MECHANICAL

parameter	conditions/description	min	typ	max	units
dimensions	enclosed: 179 x 98 x 38 enclosed with fan: 179 x 98 x 55.4				mm mm
weight	enclosed enclosed with fan		0.64 0.68		kg kg

MECHANICAL DRAWING

CNF

units: mm

CN1 Pin Connections		CN2 Pin Connections	
PIN	Function	PIN	Function
1	AC/L	PSF-155-A, PSF-155-C ³	
2	AC/N	1	AC OK
3	FG \perp	2	BAT LOW
4	-Vo1	3	PSF-155-A: (13.8 V/20 mA) PSF-155-C: (27.6 V/20 mA)
5	+Vo1	PSF-155-B, PSF-155-D ⁴	
6	+Vo2 (+ BAT)	1 2	AC OK
7 ¹	-Vo2 (- BAT)	3 4	BAT LOW
8 ²	+Vo3 (+5 V)		

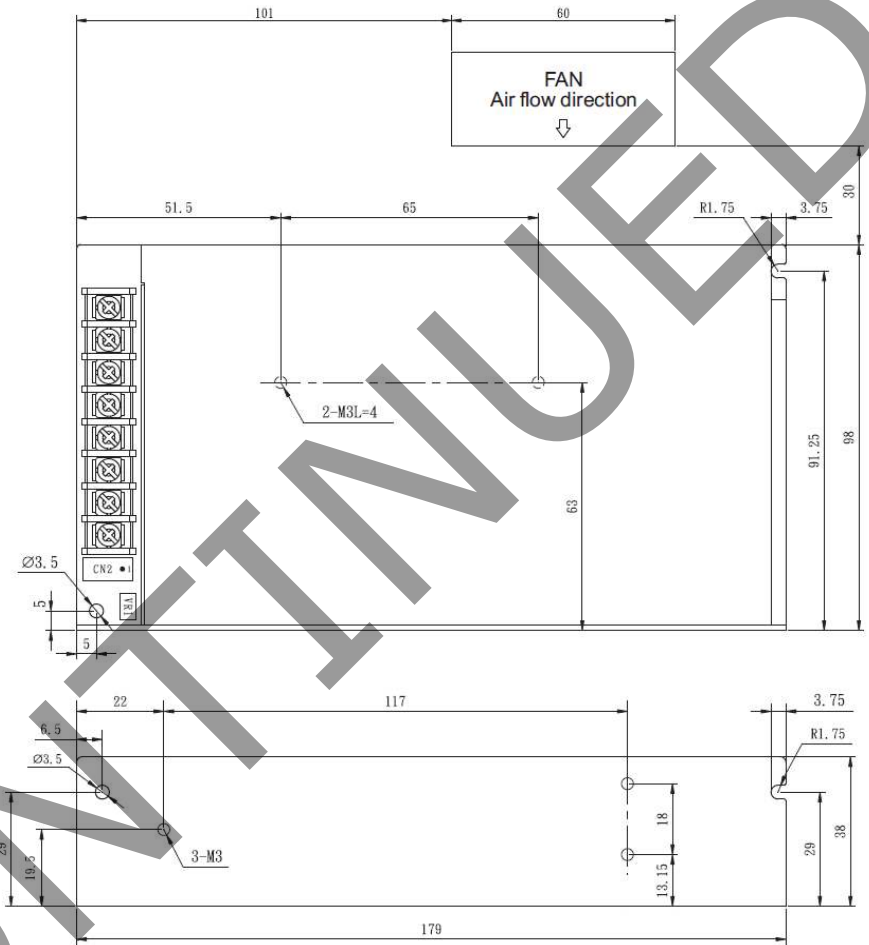

CF

units: mm

CN1 Pin Connections		CN2 Pin Connections	
PIN	Function	PIN	Function
1	AC/L	PSF-155-A, PSF-155-C ³	
2	AC/N	1	AC OK
3	FG \perp	2	BAT LOW
4	-Vo1	3	PSF-155-A: (13.8 V/20 mA) PSF-155-C: (27.6 V/20 mA)
5	+Vo1	PSF-155-B, PSF-155-D ⁴	
6	+Vo2 (+ BAT)	1 2	AC OK
7 ¹	-Vo2 (- BAT)	3 4	BAT LOW
8 ²	+Vo3 (+5 V)		

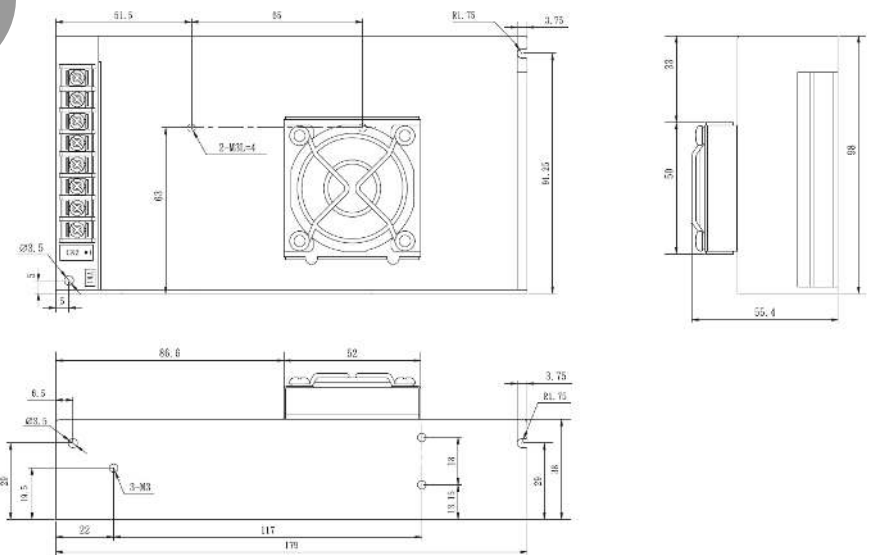

- Notes:
1. To protect product damage do not connect the GND port with -BAT port.
 2. PSF-155-B and PSF-155-D only.
 3. For PSF-155-A & PSF-155-C, CN2 mates with JST XHP-3 or equivalent and JST SXH-001 T-P0.6 or equivalent.
 4. For PSF-155-B & PSF-155-D, CN2 mates with JST XHP-4 or equivalent and JST SXH-001 T-P0.6 or equivalent.

BATTERY CHARGING SPECIFICATIONS

Block Diagram

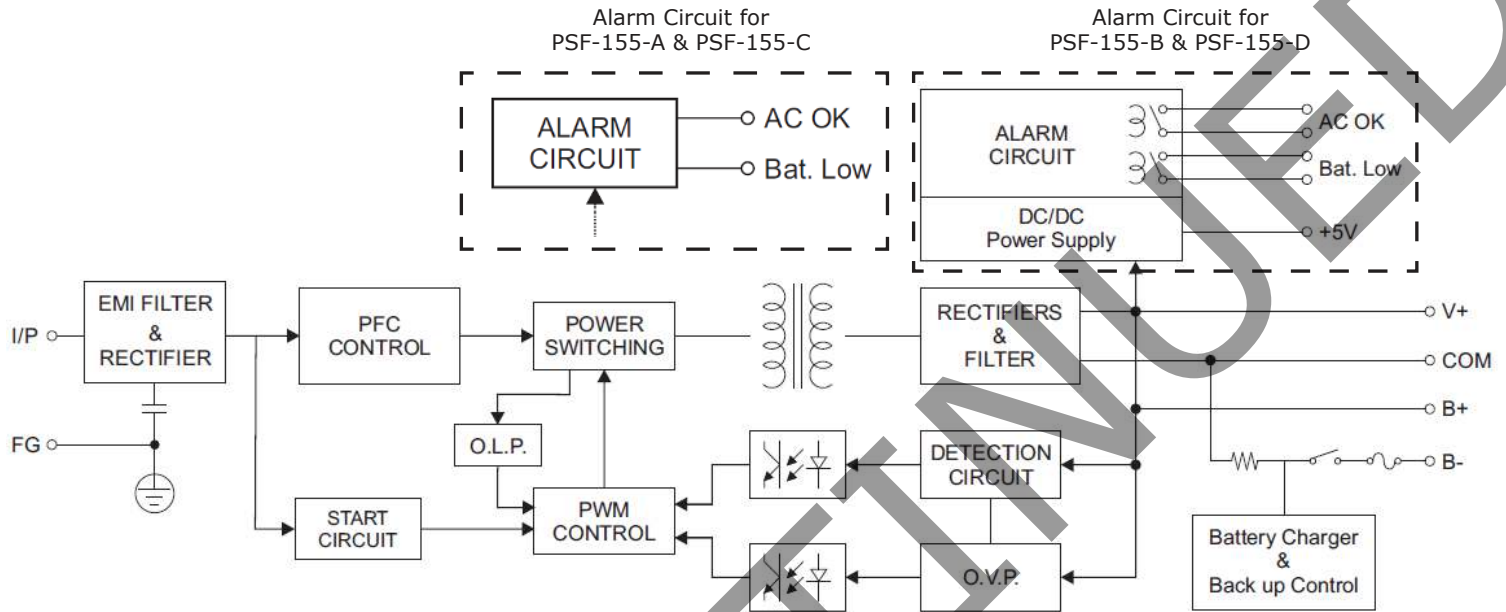

PSF-155-A & PSF-155-C

Alarm Signal for AC OK and Battery Low

Function	Description	Alarm Output
AC OK	The signal is low when the power supply turns on	Low (0.3 V max. at 30 mA)
	The signal is high when the power supply turns off	High/open (external voltage < 50 V)
Battery Low	The signal is low when the voltage of the battery is below: 12 V (PSF-155-A), 22 V (PSF-155-C)	Low (0.3 V max. at 30 mA)
	The signal is high when the voltage of the battery is above: 12 V (PSF-155-A), 22 V (PSF-155-C)	High/open (external voltage < 50 V)

- Notes:
1. Alarm signal is sent out through "AC OK" and "Battery Low" pins.
 2. An external voltage source is required for this function. The maximum applied voltage is 50 V and the maximum sink current is 30 mA.

Internal Circuit of AC OK and Battery Low

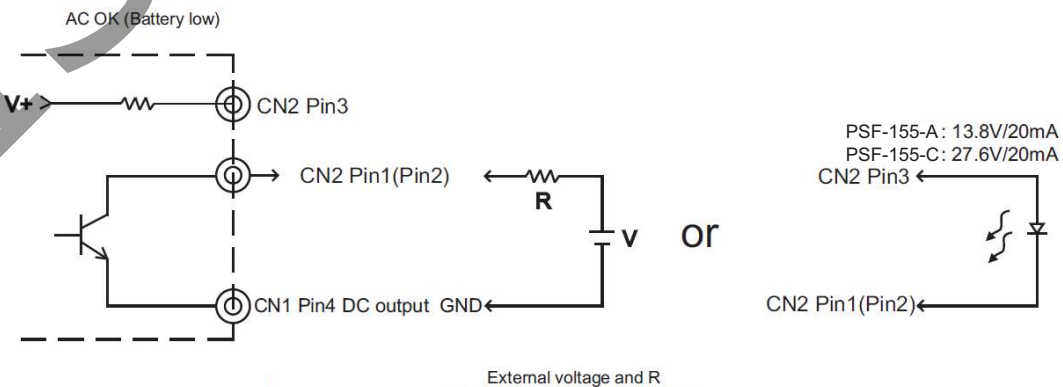

BATTERY CHARGING SPECIFICATIONS (CONTINUED)

PSF-155-B & PSF-155-D

Alarm Signal for AC OK and Battery Low

Function	Description	Alarm Output
AC OK	The signal is low when the power supply turns on	Low or short
	The signal is high when the power supply turns off	High/open (external voltage < 30 V)
Battery Low	The signal is low when the voltage of the battery is below: 12 V (PSF-155-B), 22 V (PSF-155-D)	Low or short
	The signal is high when the voltage of the battery is above: 12 V (PSF-155-B), 22 V (PSF-155-D)	High/open (external voltage < 30 V)

- Notes:
1. Alarm signal is sent out through "AC OK" and "Battery Low" pins (relay contact type).
 2. An external voltage source is required for this function. The maximum applied voltage is 30 V and the maximum sink current is 1 A.

Internal Circuit of AC OK and Battery Low

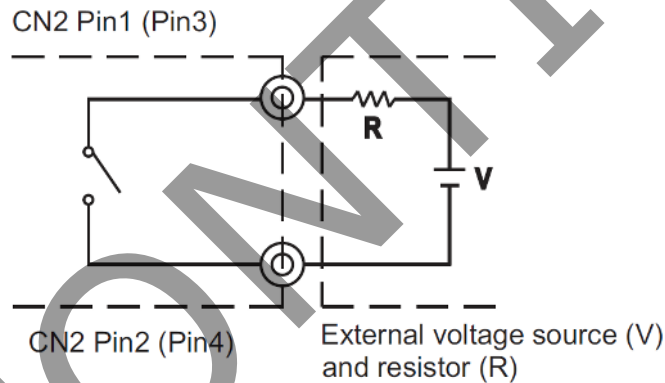

REVISION HISTORY

rev.	description	date
1.0	initial release	11/25/2013
1.01	updated datasheet	12/12/2014

The revision history provided is for informational purposes only and is believed to be accurate.



Headquarters
20050 SW 112th Ave.
Tualatin, OR 97062
800.275.4899

Fax 503.612.2383
cui.com
techsupport@cui.com

CUI offers a two (2) year limited warranty. Complete warranty information is listed on our website.

CUI reserves the right to make changes to the product at any time without notice. Information provided by CUI is believed to be accurate and reliable. However, no responsibility is assumed by CUI for its use, nor for any infringements of patents or other rights of third parties which may result from its use.

CUI products are not authorized or warranted for use as critical components in equipment that requires an extremely high level of reliability. A critical component is any component of a life support device or system whose failure to perform can be reasonably expected to cause the failure of the life support device or system, or to affect its safety or effectiveness.