

# SMA4038

NPN Darlington

With built-in flywheel diode

External dimensions ..... SMA (15-pin)

## Absolute maximum ratings

( $T_a=25^\circ\text{C}$ )

Symbol	Ratings	Unit
$V_{CBO}$	120	V
$V_{CEO}$	120	V
$V_{EBO}$	6	V
$I_C$	3	A
$I_{CP}$	5 (PW $\leq$ 1ms, Du $\leq$ 50%)	A
$I_B$	0.2	A
$I_F$	3 (PW $\leq$ 0.5ms, Du $\leq$ 25%)	A
$I_{FSM}$	5 (PW $\leq$ 10ms, Single pulse)	A
$V_R$	120	V
$P_T$	4 ( $T_a=25^\circ\text{C}$ ) 20 ( $T_c=25^\circ\text{C}$ )	W
$T_J$	150	$^\circ\text{C}$
$T_{stg}$	-40 to +150	$^\circ\text{C}$

## Electrical characteristics

( $T_a=25^\circ\text{C}$ )

Symbol	Specification			Unit	Conditions
	min	typ	max		
$I_{CBO}$			10	$\mu\text{A}$	$V_{CB}=120\text{V}$
$I_{EBO}$			10	mA	$V_{EB}=6\text{V}$
$V_{CEO}$	120			V	$I_C=25\text{mA}$
$V_{CEO(SUS)}$	120			V	$I_C=1.5\text{A}$
$h_{FE}$	2000	5000	1500		$V_{CE}=4\text{V}$ , $I_C=1.5\text{A}$
$V_{CE(sat)}$		1.1	1.5	V	$I_C=1.5\text{A}$ , $I_B=3\text{mA}$
$V_{BE(sat)}$		1.7	2.0	V	
$V_{FEC}$		1.4		V	$I_{FEC}=1.5\text{A}$
$t_{on}$		0.5		$\mu\text{s}$	$V_{CC}=30\text{V}$ , $I_C=1.5\text{A}$ ,
$t_{stg}$		2.4		$\mu\text{s}$	
$t_f$		1.0		$\mu\text{s}$	$I_{B1}=-I_{B2}=3\text{mA}$
$C_{ob}$		30		pF	$V_{CB}=10\text{V}$ , $f=1\text{MHz}$

## Equivalent circuit diagram

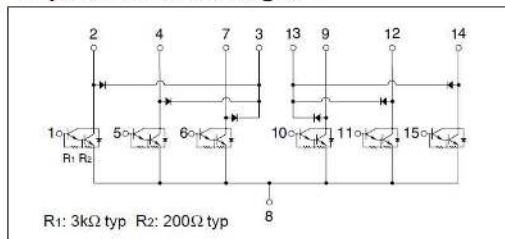

## Diode for flyback voltage absorption

( $T_a=25^\circ\text{C}$ )

Symbol	Specification			Unit	Conditions
	min	typ	max		
$V_R$	120			V	$I_R=10\mu\text{A}$
$V_F$			1.8	V	$I_F=1\text{A}$
$I_R$			10	$\mu\text{A}$	$V_R=120\text{V}$
$t_{rr}$		100		ns	$I_F=\pm 100\text{mA}$

## Characteristic curves

$I_C$ - $V_{CE}$  Characteristics (Typical)

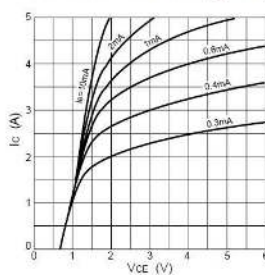

$h_{FE}$ - $I_C$  Characteristics (Typical)

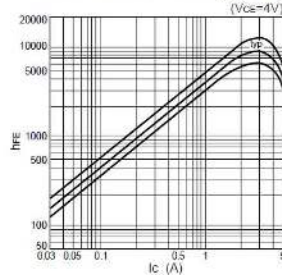

$h_{FE}$ - $I_C$  Temperature Characteristics (Typical)

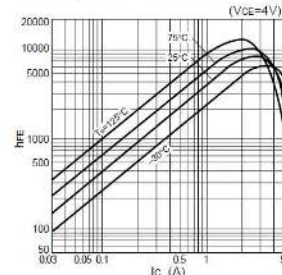

$V_{CE(sat)}$ - $I_C$  Temperature Characteristics (Typical)

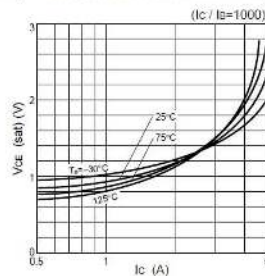

$V_{CE(sat)}$ - $I_B$  Characteristics (Typical)

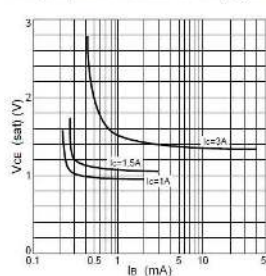

$I_C$ - $V_{BE}$  Temperature Characteristics (Typical)

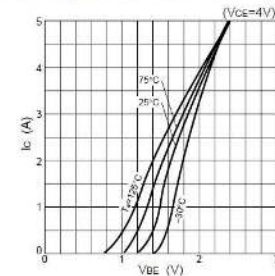

$\theta_{j-a}$ -PW Characteristics

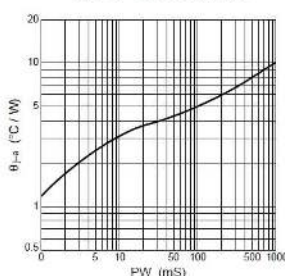

$P_T$ - $T_a$  Characteristics

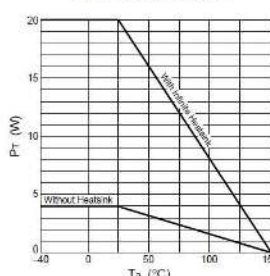

Safe Operating Area (SOA)

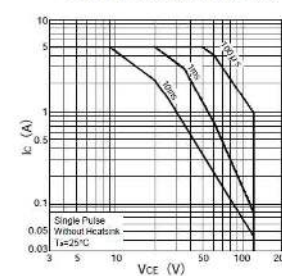

• SIP 8 (STA8Pin)

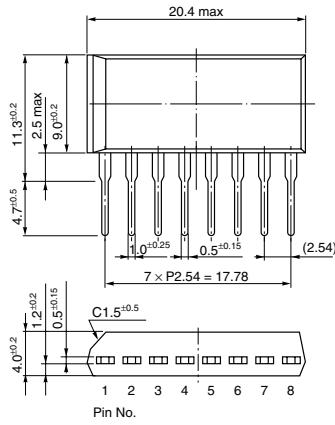

• SIP 10 (STA10Pin)

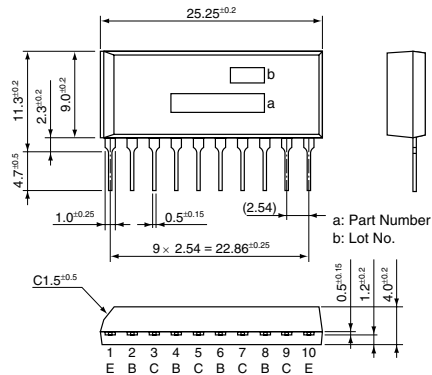

• PS 16 (Surface-Mount)

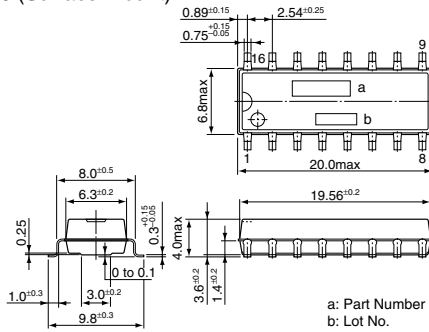

• SIP 12 (SMA12Pin)

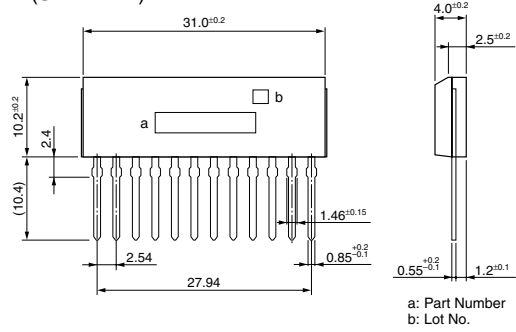

• SIP 15 (SMA15Pin)

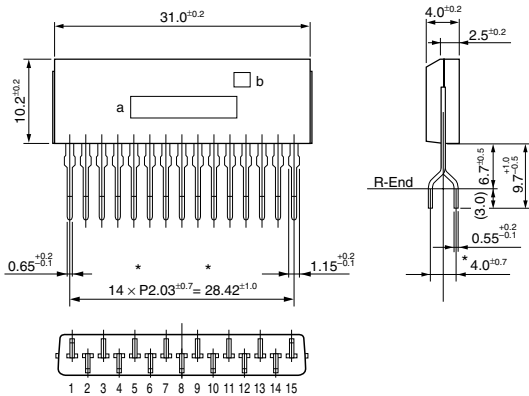

• SIP 12 with Fin (SLA12Pin)

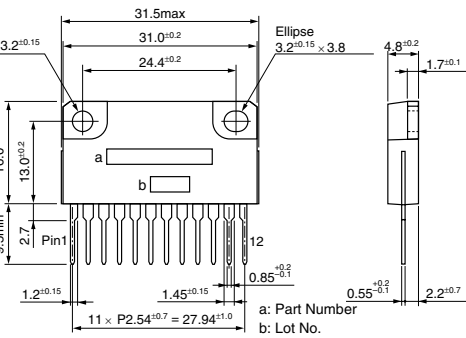

• SIP 15 with Fin (SLA15Pin)

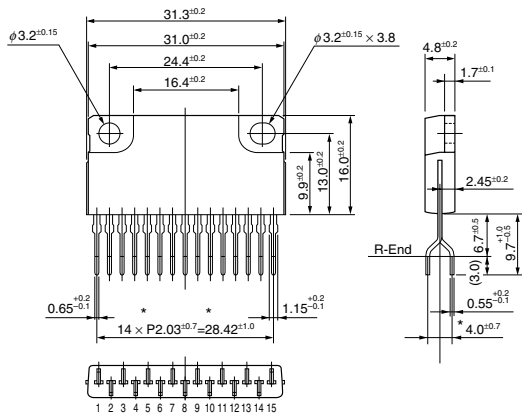

• SIP 21 with Fin (SLA21Pin)

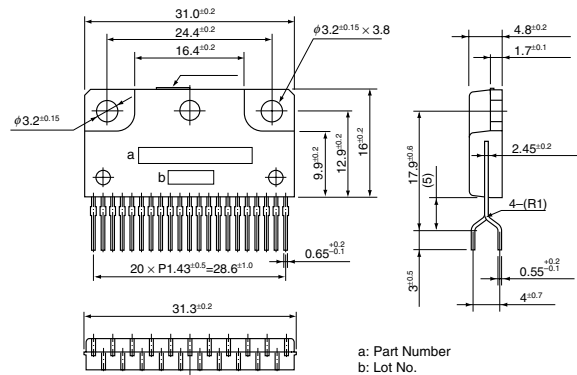

(Unit:mm)